



SIGILLANTE

**LOXEAL 4821
NERO**



**UTILIZZARE MASCHERA
CON LEVA A FRECCIA** _ 14-10-2013

Guarnizione inclusa
nella ghiera

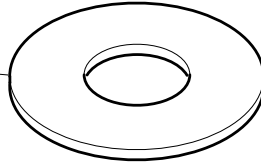

QJB4676-1/4-NYR

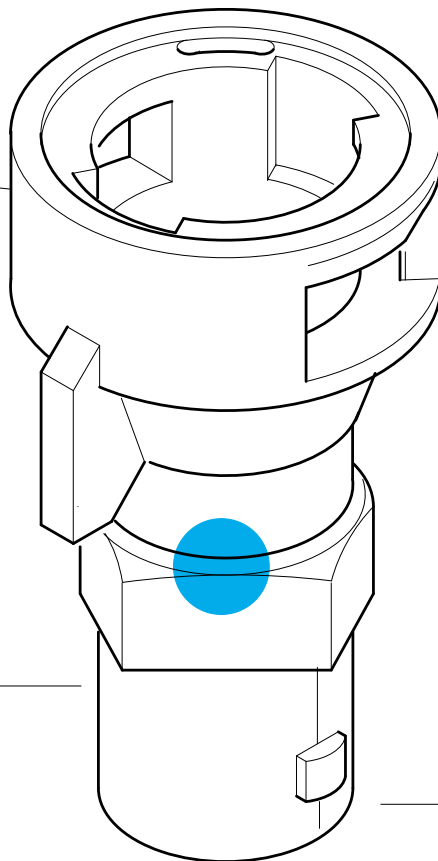

62

902048

Nota per produzione:

Buste da 10 pz

DATA: 07/05/2018

902037 - Prolunga 45mm Quick Cap

CARTELLA_ Esplosi Adattatori

DATA: 19/04/2011

QUESTO DISEGNO E' DI NOSTRA PROPRIETA', PERTANTO SENZA NOSTRA AUTORIZZAZIONE NE E' VIETATA LA RIPRODUZIONE E LA COMUNICAZIONE A TERZI, IN TERMINI DI LEGGE.
THIS DRAWING IS OF OUR OWNERSHIP, THEREFORE WITHOUT OUR AUTHORIZATION THE REPRODUCTION AND THE COMMUNICATION TO THIRDS PARTY ARE PROHIBITED, IN TERMS OF LAW.