

Portafusibile
15 A

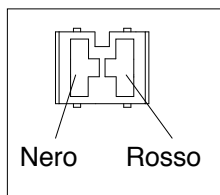

Bloccetto
2 poli
M.p.F

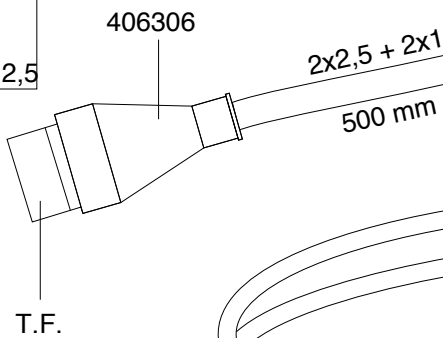
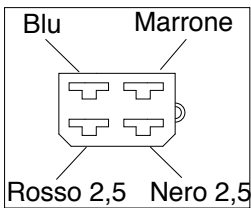
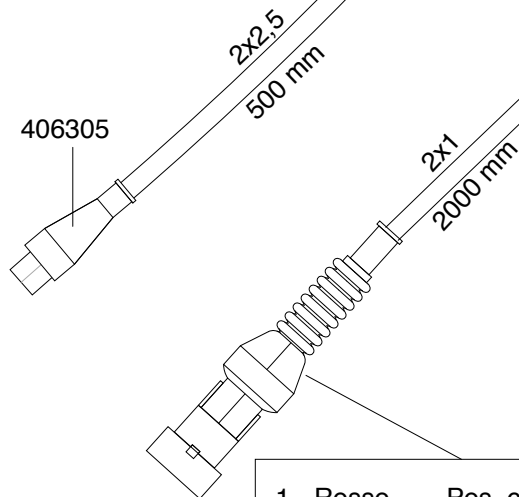

1 - Rosso -Pos. comando sx
2 - Nero -Pos. comando dx

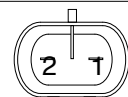

DATA	MODIFICA	Nome	DATA	MODIFICA	Nome

Salvarani

**ADATTATORE COLLEG.COMPUTER
T.F. SALVARANI**

Rif.Cod. _____

Cod. 901238

CARTELLA _S.T._CODIFICATI

DATA 03/12/2020

QUESTO DISEGNO E' DI NOSTRA PROPRIETA', PERTANTO SENZA NOSTRA AUTORIZZAZIONE NE E' VIETATA LA RIPRODUZIONE E LA COMUNICAZIONE A TERZI, IN TERMINI DI LEGGE.
THIS DRAWING IS OF OUR OWNERSHIP, THEREFORE WITHOUT OUR AUTHORIZATION THE REPRODUCTION AND THE COMMUNICATION TO THIRDS PARTY ARE PROHIBITED, IN TERMS OF LAW.