

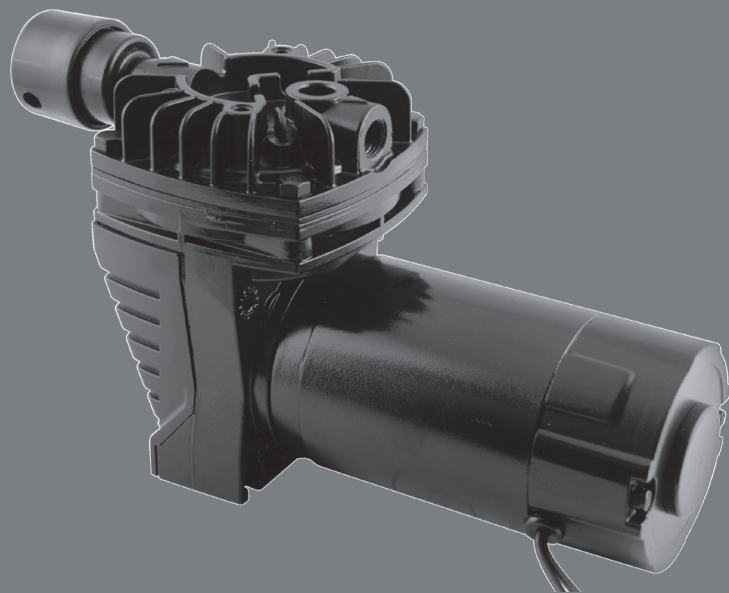

2024

COMPRESSORS



Salvarani

INNOVATION IS OUR NATURE

La nostra storia

La mia storia inizia nel 1970, ero ragazzo e con i miei genitori Giovanna ed Italo che lavoravano in un'importante azienda di irroratrici, "Carpi Pompe",
Li aiutavo dopo la scuola e con loro visitavo le fiere di settore. Finiti gli studi ho iniziato a lavorare nella medesima azienda sulle macchine innovative, come la "scatola nera" e i controlli elettronici. A quel tempo quelle macchine erano le più evolute del mercato italiano, e montavano un "TracciaFile" di importazione USA. Ho visto in questo prodotto un'innovazione per far nascere una mia azienda.

Pier Giorgio Salvarani

Salvarani nasce nel 1983 in un Garage a Poviglio nel cuore dell'Emilia Romagna, regione che vanta una lunga storia nel campo delle macchine agricole e dei loro componenti

Primo tracciafile prodotto in Italia

Serbatoi lavamani e striscianti

Distribuzione ugelli TeeJet

1983

1985

1986

1992

1995

Elettronica DPA Spraymatic e comandi elettrici

Distribuzione Centraline meteo Davis

I NOSTRI VALORI



INNOVAZIONE
Innovation

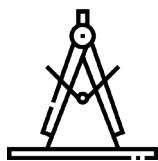

PRECISIONE
DI LAVORO
Working precision



AFFIDABILITA'
DEL PRODOTTO
Product reliability



ASSISTENZA
POST VENDITA
Assistance after sale



TUTELA
ALL' AMBIENTE
Environmental protection

L'AZIENDA HA 2 SEDI IN EUROPA:



Salvarani s.r.l. Sede centrale Poviglio (Reggio Emilia), Italia

Salvarani Rom, Romania

MARCHI IN VENDITA:

Salvarani affianca alla propria produzione alcuni marchi in esclusiva per il mercato italiano:
TeeJet® per ugelli e accessori per l'irrorazione,
SHURflo® per pompe a membrana 12V,
Davis Instruments® per le centraline meteorologiche,
Aams

TeeJet
TECHNOLOGIES

DAVIS
Davis Instruments

AAMS

SHURflo

Salvarani history

My story begins in 1970. I was a young boy and my parents Giovanna and Italo were working for an important sprayer manufacturer, "Carpi Pompe". For this reason, we were often talking about these products and after the school I used to help my father and visit trade fairs with him. After my studies I started working in the same company in the department dedicated to innovative machines, such as the "black box" and electronic controllers. At that time, those machines were among the most advanced ones on the Italian market, and were mounting a "foam marker" imported from the US. There I saw an innovation to start a company.

Pier Giorgio Salvarani

Salvarani company starts in 1983 in a garage in Poviglio in the heart of Emilia Romagna, a region which boasts a long history in agricultural machinery and its components.

Salvarani supports its production with some exclusive brands for the Italian market: TeeJet® with nozzles and spraying accessories, SHURflo® with 12 Volt diaphragm pumps and Davis Instruments® with weather stations.

The company has 2 offices in Europe:

Salvarani s.r.l. Head office in Poviglio (Reggio Emilia), Italy
Salvarani Rom in Romania

Diaphragm & Piston Compressors



Compressore a membrana
Diaphragm compressor



Compressore a pistone
Piston compressor



Funzionamento a secco
No oil required

Specifiche tecniche

 **Compressore con funzionamento a secco**, disponibile nelle versioni a membrana e a pistone.

I numerosi test condotti hanno confermato che nei compressori OIL LESS la qualità dell'aria in uscita è identica a quella in entrata, in nessun caso il compressore aggiunge contaminanti al gas che viene pompato.

Il fatto di non aver alcun componente in bagno d'olio rende inoltre la manutenzione molto più semplice: lo smontaggio e il riassetto risultano infatti elementari.

Per garantire una maggiore flessibilità d'utilizzo, la testa del compressore è orientabile di 90° in 90°.

Technical features

 **Dry compressor** available as a diaphragm or piston type.

Numerous tests have demonstrated that with OIL LESS compressors, the quality of the air emitted is identical to that of the inlet air; the compressor never adds any contaminants to the pumped gas.

Maintenance is made much simpler as there are no parts with oil bath lubrication; removal and replacement are extremely easy.

To guarantee greater operating flexibility, the angle of the compressor head can be adjusted in 90° steps.

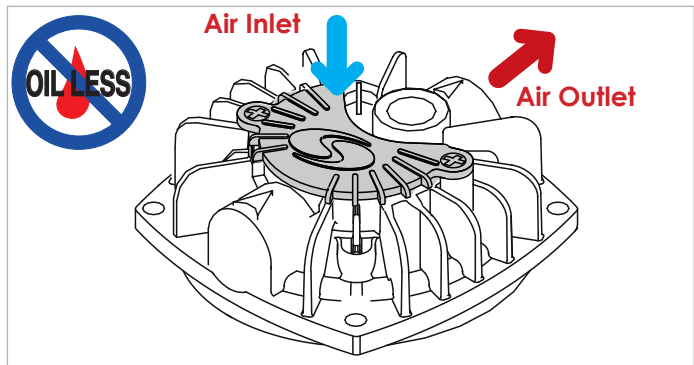
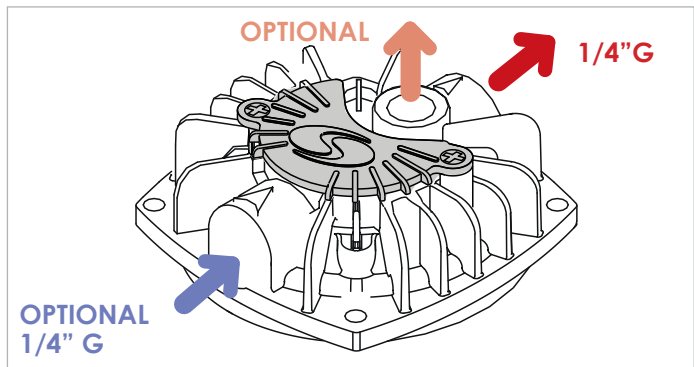

Compressore a membrana

Diaphragm compressor



Compressore a pistone

Piston compressor

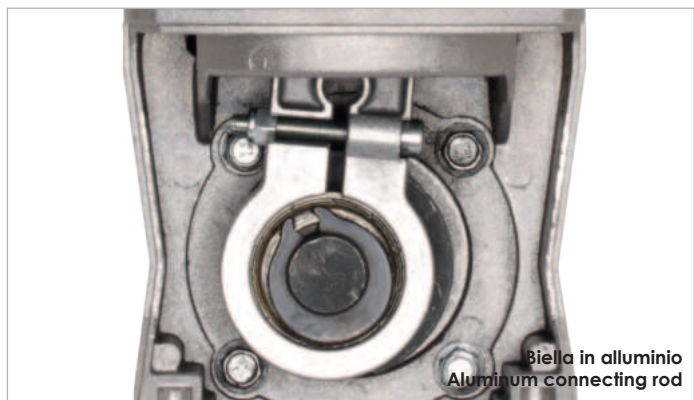
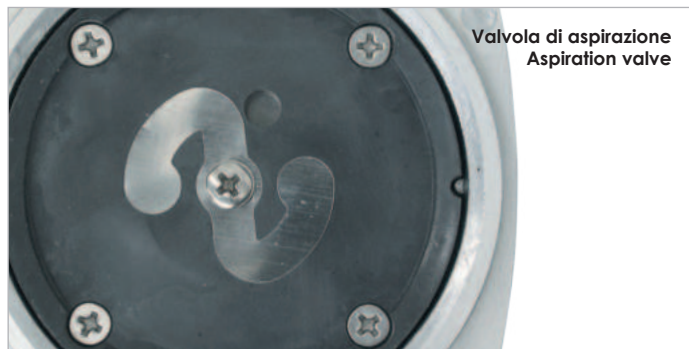

CM 40/60 - Compressori a Membrana

CM 40/60 - Diaphragm Compressors

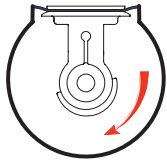
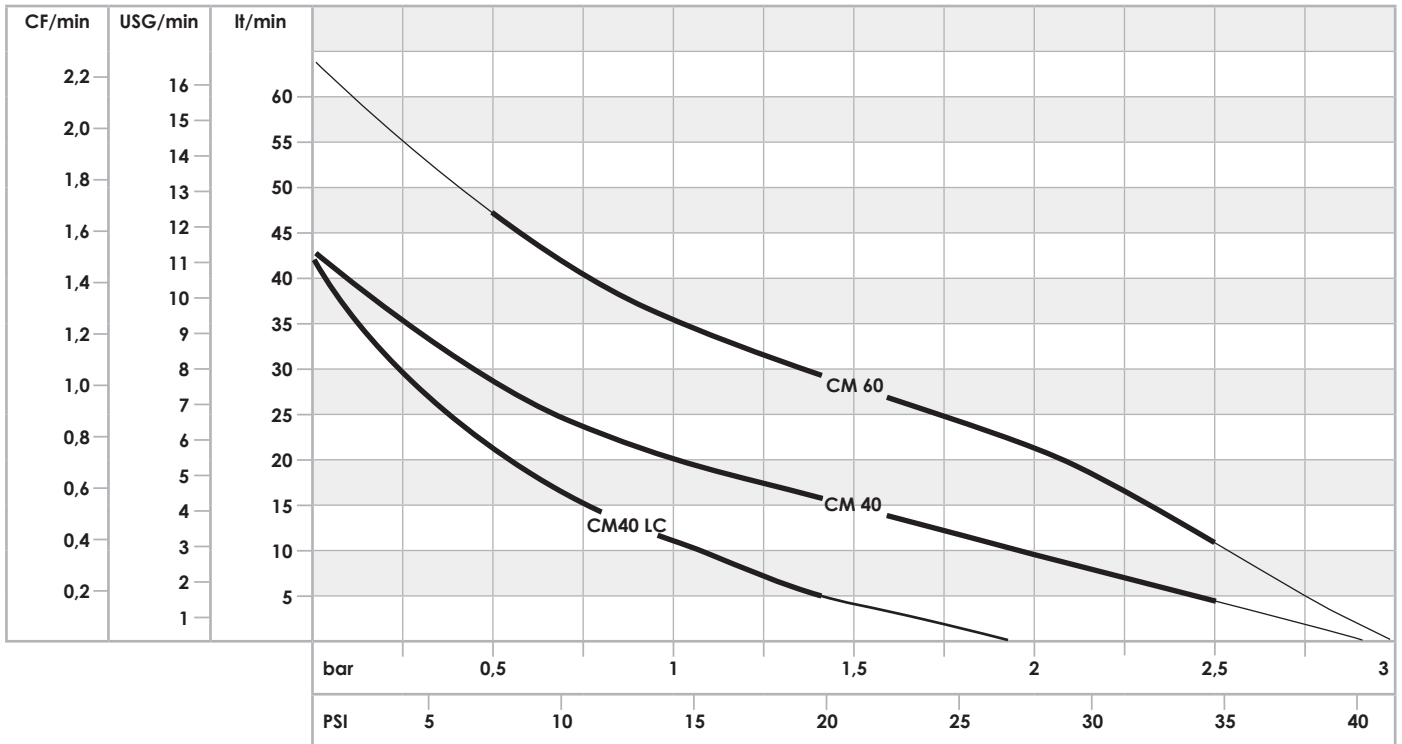

	CM40 LC	CM40	CM60
Max Flow (l/min)	40	40	60
A Max	5	7,8	13
Max Pressure (bar (PSI))	1,8 (26)	2,8 (40,6)	2,8 (40,6)

Specifiche compressori a membrana

- Testa: Alluminio
- Corpo: Alluminio
- Flangia valvole: Tecnopolimero
- Valvole: Acciaio Inox
- Biella: Tecnopolimero
- Eccentrico: Acciaio

Tutti i movimenti rotazionali del gruppo pompante sono su cuscinetti a sfera autolubrificanti.

Specifications of diaphragm compressors

- Head: Aluminum
- Body: Aluminum
- Flange of the valves: Technopolymer
- Valves : Stainless Steel
- Connecting rod: Technopolymer
- Cam: Steel

All rotational movements of the pumping unit are on self-lubricating ball bearings.

CP15/26/37/45 - Compressori a Pistone

CP15/26/37/45 - Piston Compressors

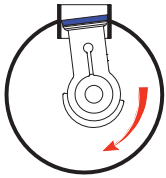
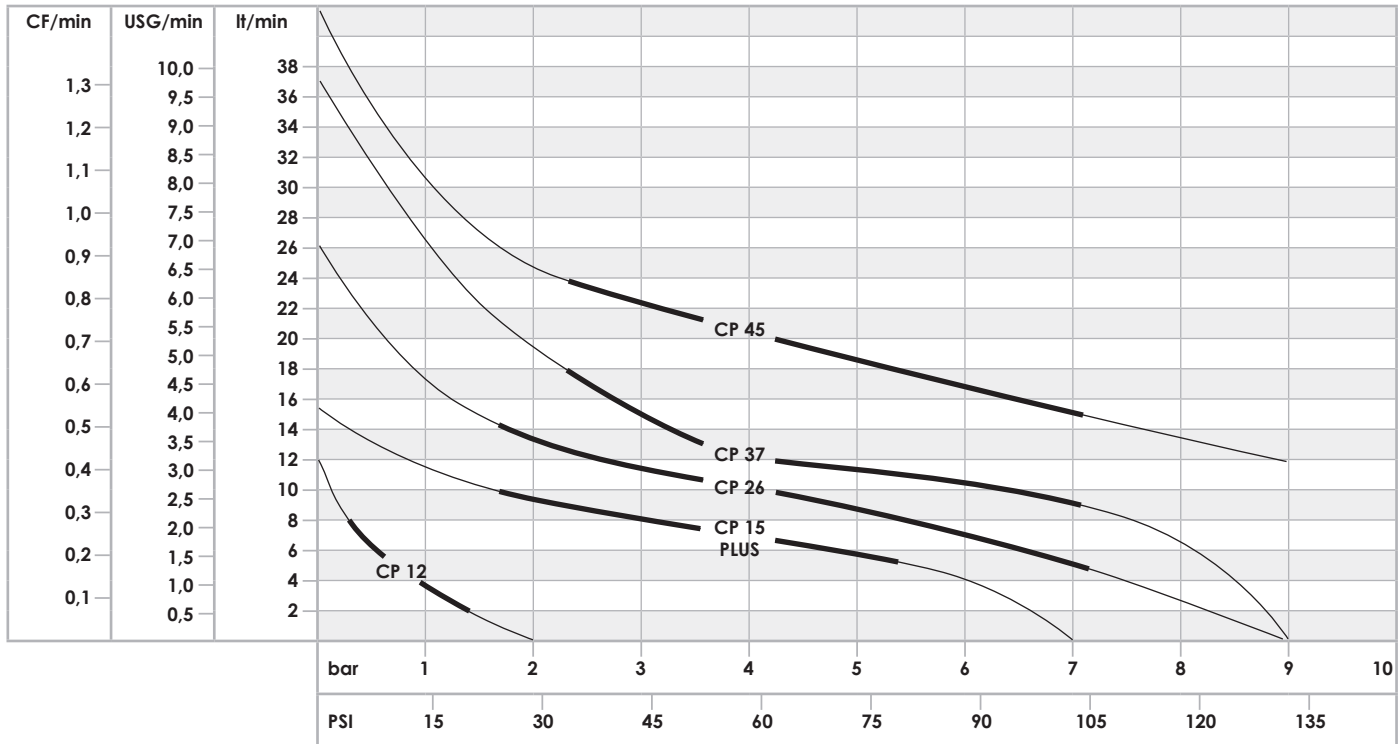

	CP12	CP15 PLUS	CP26	CP37	CP45
Max Flow (l/min)	12	15	26	37	45
A Max	2,5	6	8,5	14,5	20
Max Pressure (bar (PSI))	2 (29)	7 (101)	9 (130)	9 (130)	9 (130)

Specifiche compressori a pistone

- Testa: Alluminio
- Corpo: Alluminio
- Flangia valvole: Alluminio
- Valvole: Acciaio inox
- Biella: Alluminio
- Eccentrico: Acciaio

Tutti i movimenti rotazionali del gruppo pompante sono su cuscinetti a sfera autolubrificanti.

Specifications of piston compressors

- Head: Aluminum
- Body: Aluminum
- Flange of the valves : Aluminum
- Valve: stainless steel
- Connecting rod: Aluminum
- Cam: Steel

All rotational movements of the pumping unit are on self-lubricating ball bearings.

■ Guida alla scelta del compressore

🇬🇧 Compressor's selection guide

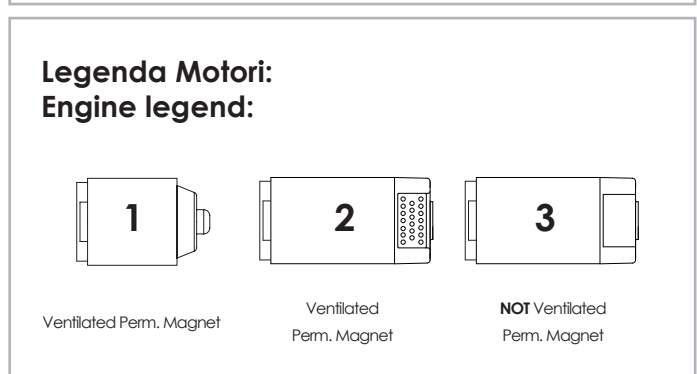
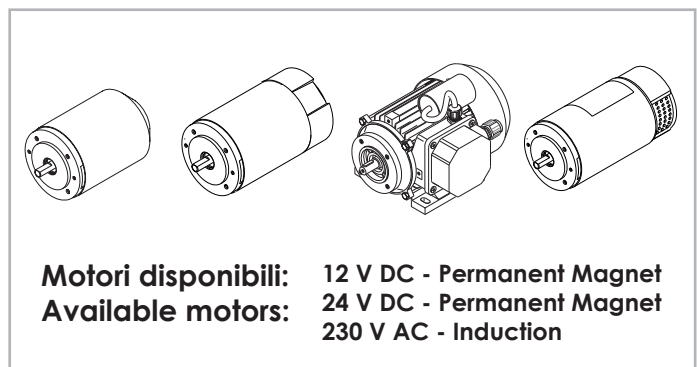
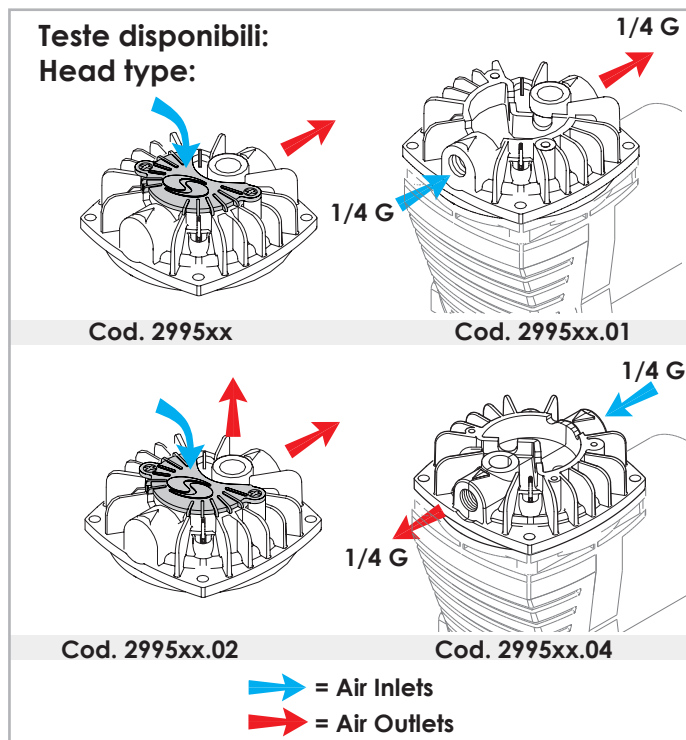

Modelli a Membrana / Diaphragm models

	Available versions	Motor Type			V (V)	I (A)	Speed (rpm)	Power (W)	Service Duty cycle (@ 2 bar - 22 °C)	IP Protection	Suction Filter	Weight (kg)
		Ventilated Perm. Magnet	NOT Ventilated Perm. Magnet	Ventilated Induction								
CM 40	299501	•			12 DC	7,8	2000	65	100%	20	•	2,4
	299501.04 NPT	•			12 DC	7,8	2000	65	100%	20		2,4
CM 60	299505.01	•			12 DC	13	3000	110	100%	20		2,6
	299513.01	•			24 DC	6,5	3000	110	100%	20	•	2,6

Modelli a Pistone / Piston models

	Available versions	Motor Type			V (V)	I (A)	Speed (rpm)	Power (W)	Service Duty cycle (@ 7 bar - 22 °C)		IP Protection (DIN EN 60529)	Suction Filter	Weight (kg)
		1 Ventilated Perm. Magnet	2 NOT Ventilated Perm. Magnet	3 Ventilated Induction									
CP 12	299047	•			12 DC	2,5		24	100%		20		0,55
CP 15 PLUS	299528.01	•			12 DC	6	2000	45	100%		20		2,4
CP 26	299503	•			12 DC	8,5	2000	75	60%	20' ON - 13' OFF	20	•	2,4
CP 37	299504	•			12 DC	14,5	3000	130	60%	20' ON - 13' OFF	20	•	2,5
	299504.01	•			12 DC	14,5	3000	130	60%	20' ON - 13' OFF	20		2,5
	299533		•		12 DC	14,5	3000	130	40%	10' ON - 15' OFF	54		2,5
	299520.01			•	230 AC	0,9	2800	130	100%		44		3,8
CP 45	299509	•			12 DC	20	3700	180	50%	20' ON - 20' OFF	20	•	2,5
	299509.01	•			12 DC	20	3700	180	50%	20' ON - 20' OFF	20		2,5
	299511.01	•			24 DC	11	3700	180	50%	20' ON - 20' OFF	20		2,5

Specifiche compressori a Pistone

- Testa: Tecnopolimero
- Corpo: Tecnopolimero
- Flangia valvole: Tecnopolimero
- Valvole: NBR
- Biella: Tecnopolimero
- Cilindro: Tecnopolimero
- Eccentrico: Ottone

Specifications of piston compressors

- Head: Technopolymer
- Body: Technopolymer
- Flange of the valves: Technopolymer
- Valves : NBR
- Connecting rod: Technopolymer
- Cylinder: Technopolymer
- Cam: Brass

Compressore a Pistone 299047

299047 Piston Compressor

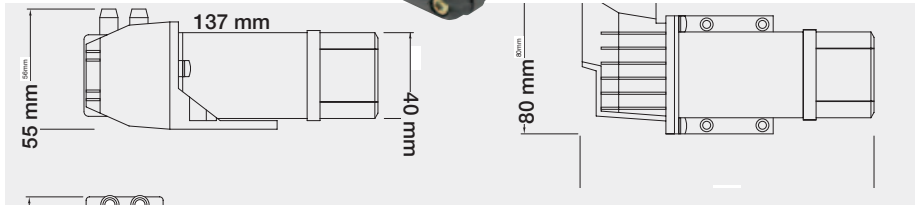
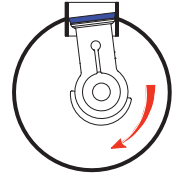

299047

Motor Type	Permanent magnet
V (V)	12
I (A)	2
Power (W)	24
Service (Duty Cycle)	S3 (50%) (Temp 20 °C - Press 1 bar)
IP protection	20
Weight (Kg)	0,550

CM 40/60 - Selezione serbatoi

CM 40/60 - Air Tank Selection



	20 lt 5,25 USG	40 lt 10,56 USG	60 lt 15,85 USG	80 lt 21,13 USG
Pressione da 0 a 1,5 bar Pressure 0 to 21,75 PSI				
CM 40	1 min 30 sec	3 min	4 min 30 sec	6 min
CM 60	56 sec	1 min 53 sec	2 min 48 sec	3 min 44 sec

CP 15/26/37/45 - Selezione serbatoi

CP 15/26/37/45 - Air Tank Selection



	2 lt 0,5 USG	5 lt 1 USG	10 lt 2,6 USG	15 lt 4 USG
Pressione da 0 a 5 bar Pressure 0 to 72 PSI				
CP 15	1 min 30 sec	3 min 40 sec	7 min	10 min 20 sec
CP 26	54 sec	2 min 15 sec	4 min 25 sec	7 min
CP 37	40 sec	1 min 40 sec	3 min 30 sec	5 min
CP 45	31 sec	1 min 15 sec	2 min 40 sec	4 min
Pressione da 0 a 7 bar Pressure 0 to 100 PSI				
CP 26	1 min 30 sec	3 min 50 sec	7 min 25 sec	11 min 20 sec
CP 37	1 min 6 sec	2 min 50 sec	5 min 30 sec	8 min 10 sec
CP 45	48 sec	2 min	4 min	6 min

CM 40/60 - Compressori a Membrana

CM 40/60 - Diaphragm Compressors

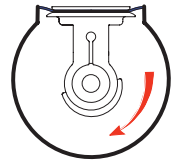

Mod.	Volt	Motor
CM40	12V	299079
CM40 I/O	12V	299079.01
CM40 90°	12V	299079.02
CM60	12V	299079
CM60 I/O	12V	299079.01
CM60	24V	299079
CM60	230VAC	299079

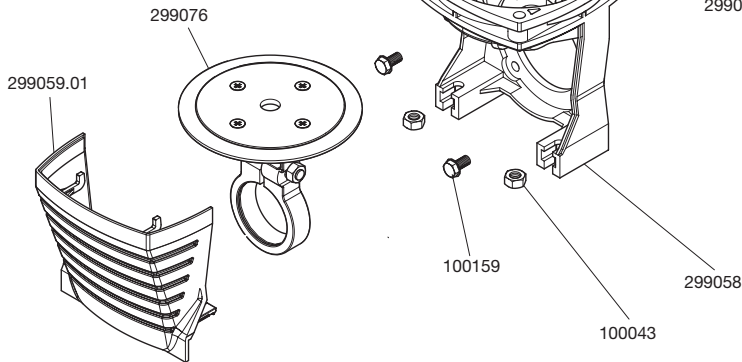
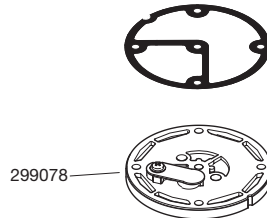
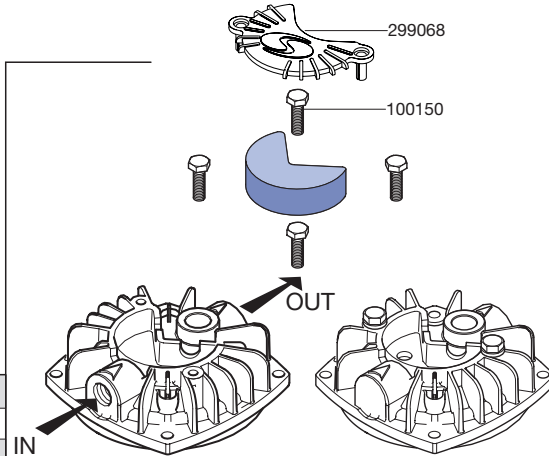

Mod.	Volt	Motor
CM40	12V	299050.03
CM60	12V	299050.01
CM60	24V	299073

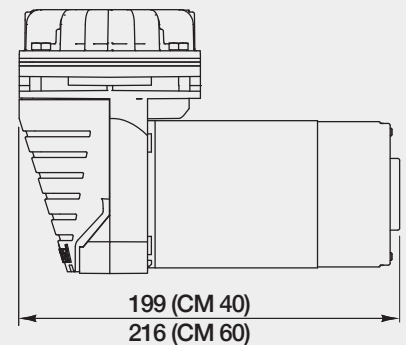
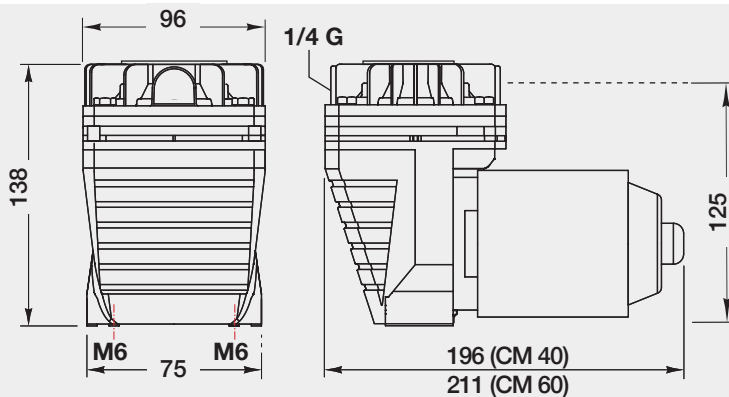

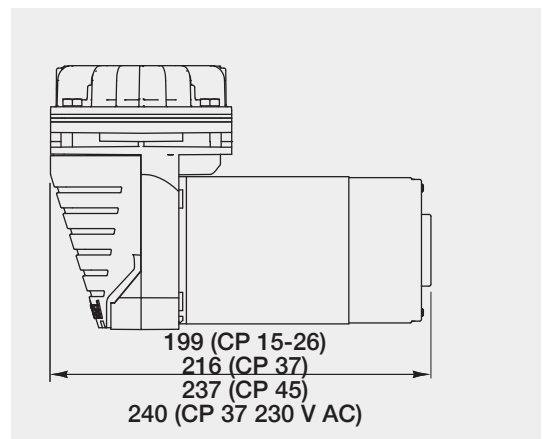
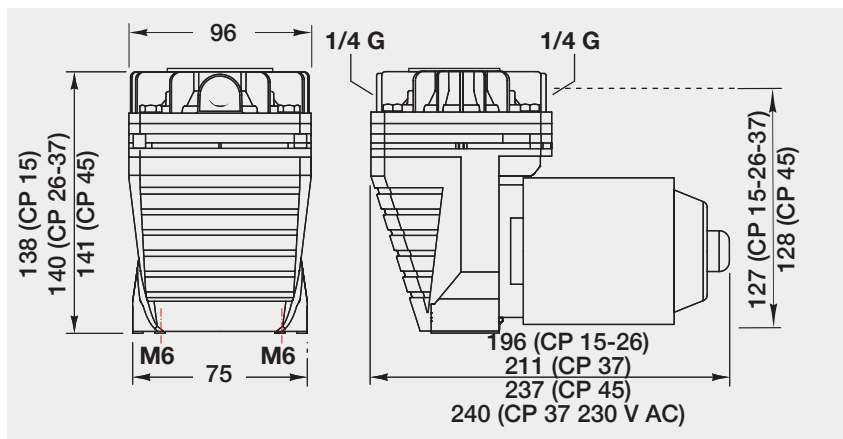
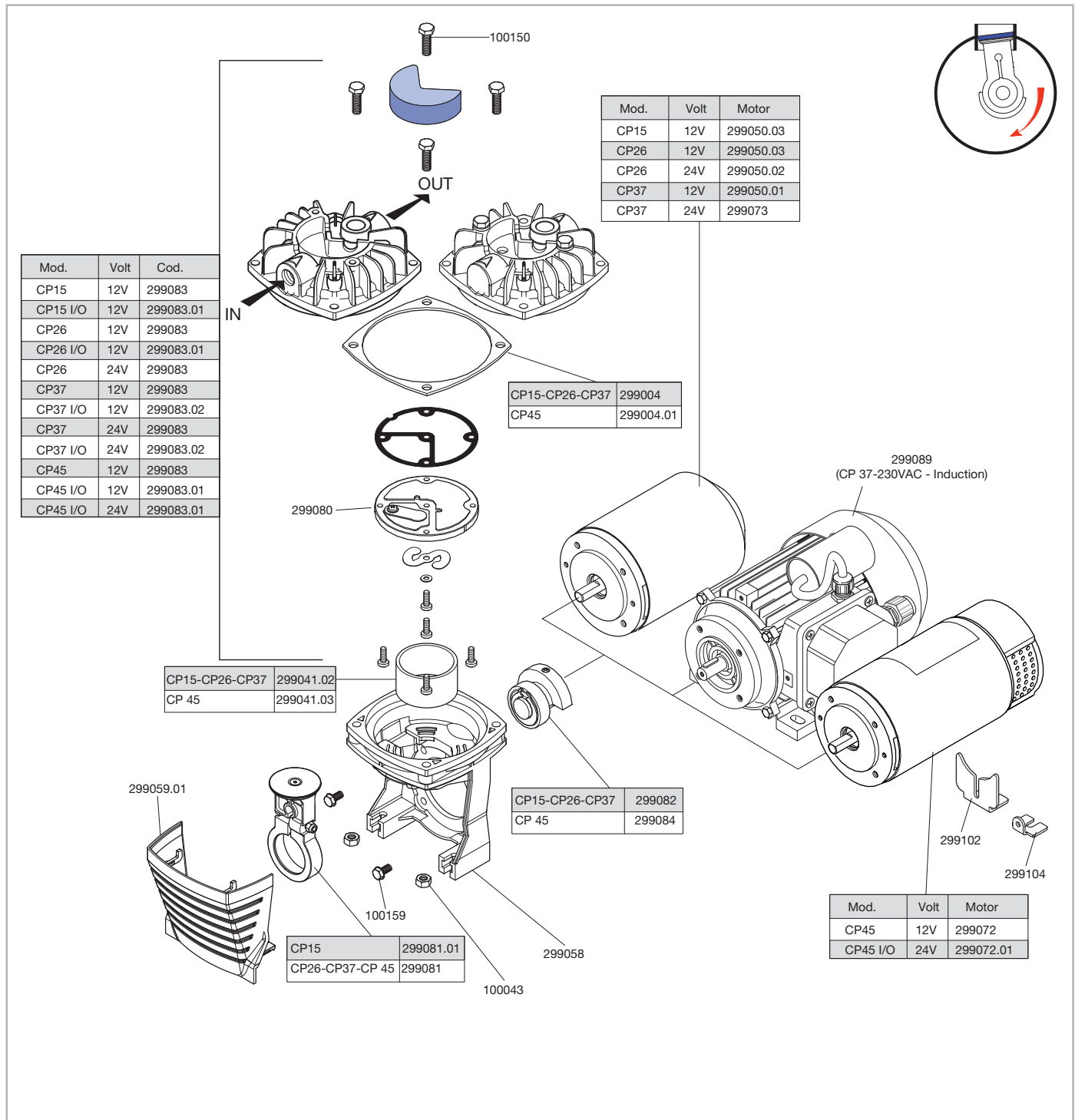

CP15/26/37/45 - Compressori a Pistone

CP15/26/37/45 - Piston Compressors



Air power black

 CP37 12 V compressor; model with motor, body and head in aluminum completely painted, suitable for outdoor use. To be used in connection with a pressure switch (available as an option) and a 15litri or higher tank. Suitable for anti-drip tires, air suspension, similar applications.

 Compressore CP37 12 Volts; modello con motore, corpo e testa in alluminio completamente verniciati, adatto ad un uso esterno. Da utilizzare in collegamento ad un pressostato (optional disponibile) e serbatoio da 15 litri o superiore. Adatto ad antigoccia pneumatici, sospensioni pneumatiche, applicazioni similari.



299537

Cod.	Model	Service Duty cycle (@ 7 bsr - 22°C)		Max Flow (l/min)	Max Pressure (bar (PSI))		I Max (A)
		S3 (40%)	10' ON - 15' OFF				
299537	Air Power Black CP37	S3 (40%)	10' ON - 15' OFF	37	9 (130)	12 V DC	14,5

Air Power One

 Oil free unit producing compressed air, suitable to provide compressed air for several applications on mobile vehicles.

Ideally to be combined with an accumulation tank from 10 - 30 lt.

- Compressor kit includes a piston compressor without lubrication CP37 - CP45;
- Adjustable pressure switch from 5 to 8 bar;
- Battery cable with fuse;
- Duty cycle 40% - 10 min. ON, 15 min. OFF.
- Termic-equipped model available

 Modulo specifico a 12 Volts e unità produttrice di aria compressa a secco adatto a poter fornire su un mezzo mobile aria in pressione per utilizzi diversi. Per prestazioni ottimali si consiglia di abbinarlo ad un serbatoio di accumulo da 10-30 lt.

- Gruppo composto da compressore a pistone senza lubrificazione CP37-CP45;
- pressostato regolabile con regolazione da 5 a 8 bar;
- cavo collegamento batteria con fusibile;
- Duty cycle 40% - 10 min. ON, 15 min. OFF.
- Modello disponibile anche con termica



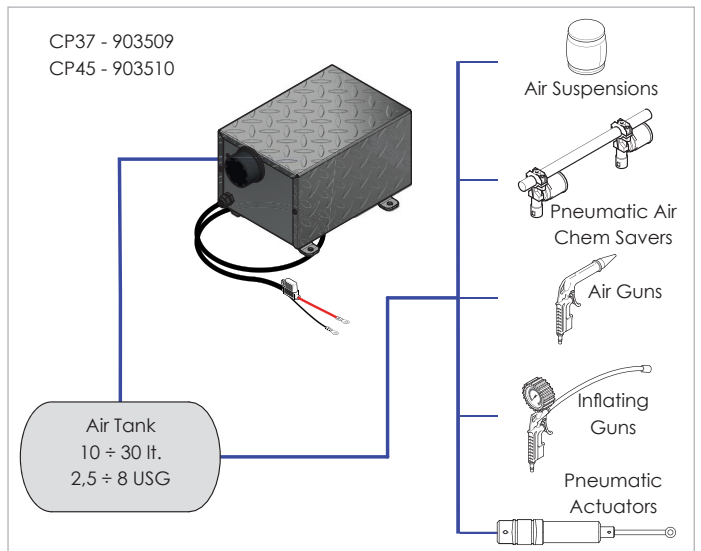

903509



CP37 - 903509
CP45 - 903510

Tank (lt)	Compressor Filling Time	
	CP37 da 0 a 7 bar	CP45 da 0 a 7 bar
10	5 min	4 min
20	11 min	8 min

Cod.	Model	Flow (l/min)	 bar (PSI)	Duty cycle		I Max (A)
903510	Air Power two CP45	45	0-7 (0-101,5)	40%	12 V DC	20

Bale Adjuster

 The Bale Adjuster kit consists of a compressor and a maneuvering control panel with a manometer.

The compressor, once operated, provides compressed air at 7 bar pressure, which can be sent to a tank (not supplied).

At start-up, the air pressure in the tank is brought to 7 bar; Then pushing the control lever momentarily, the pressure is reduced to the desired value, which can be controlled on the manometer.

In this way, the tank air can be used to exert constant pressure on the walls of the hay bale forming chamber during their compacting, generating them with an ideal density.





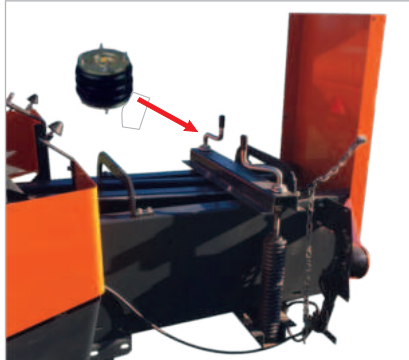

This easily adapts to the different conditions of hay. Similar systems, made with springs or hydraulic systems, require continuous adaptations that cause breaks during work, as small differences in hay conditions create big differences

 Il kit Bale Adjuster è formato da un compressore e da un quadro di azionamento fornito di manometro. Il compressore, una volta azionato, fornisce aria compressa alla pressione di 7 bar, che può essere inviata ad un serbatoio (non fornito).

All'accensione, la pressione dell'aria nel serbatoio viene portata a 7 bar; azionando poi la leva del quadro in posizione momentanea, la pressione viene ridotta fino al valore desiderato, controllabile sul manometro.

In tal modo l'aria del serbatoio può essere utilizzata per esercitare una pressione costante sulle pareti della camera di formazione delle balle di fieno durante il loro compattamento, generandole con una densità ideale. Questa si adatta facilmente alle diverse condizioni del fieno. Analoghi sistemi, realizzati con molle o sistemi idraulici, richiedono continui adattamenti che provocano interruzioni durante il lavoro, in quanto piccole differenze nelle condizioni del fieno creano grandi differenze nella composizione delle balle.



Cod.	Model						
		7m	✓	2m	-	39x24x34 (cm)	7 (Kg)
901809.01	Kit Bale Adjuster						

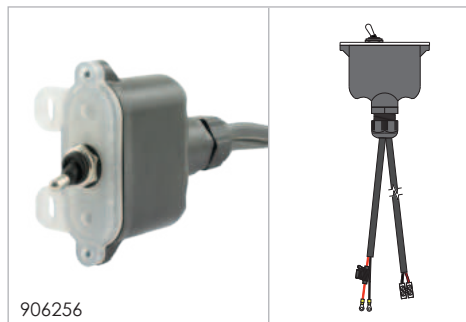





906256



906431



906256

Cod.		A		Model			Fuse (A)	
906256	1	15A	-	Kit Box Pump ECO	✓	eyelets	15	12 V DC
906431	1	15A		Kit Box PMP P45	✓	 2m/78"	15	12 V DC
906438	1	15A	✓	Kit Box 15A - Sensore P90	✓	 2m/78"	15	12 V DC

Tank

 A 5lt aluminum tank model, and 3 carbon steel models, painted in RAL 5015, with capacity from 5 to 15lt, maximum pressure 8-11 bar.

Designed for use in conjunction with Salvarani compressors.

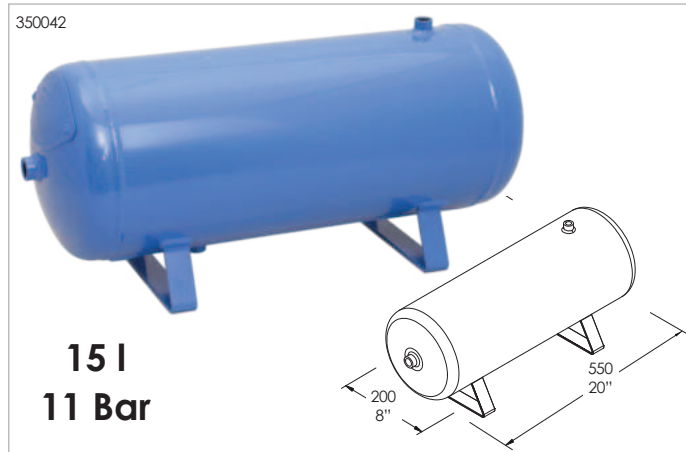
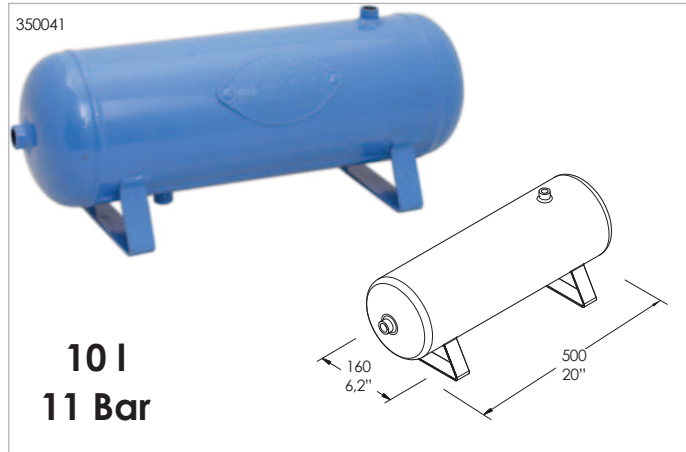
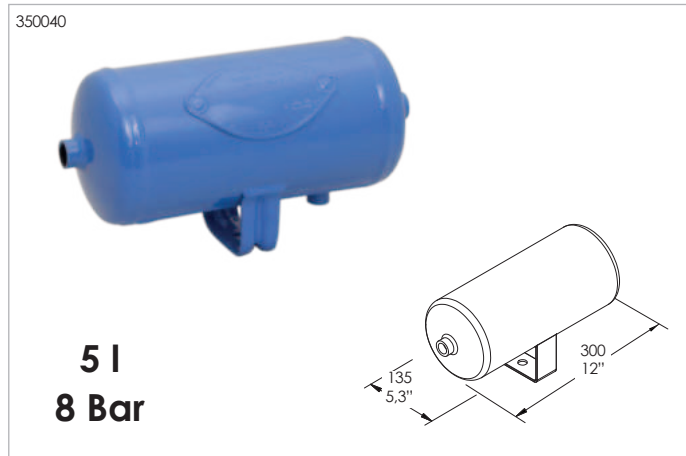

Serbatoi

 Un modello di serbatoio in alluminio da 5lt, e 3 modelli in acciaio al carbonio, verniciati in RAL 5015, con capacità da 5 a 15lt, pressione massima 8-11 bar.

Studiati per l'utilizzo in abbinamento ai compressori Salvarani.

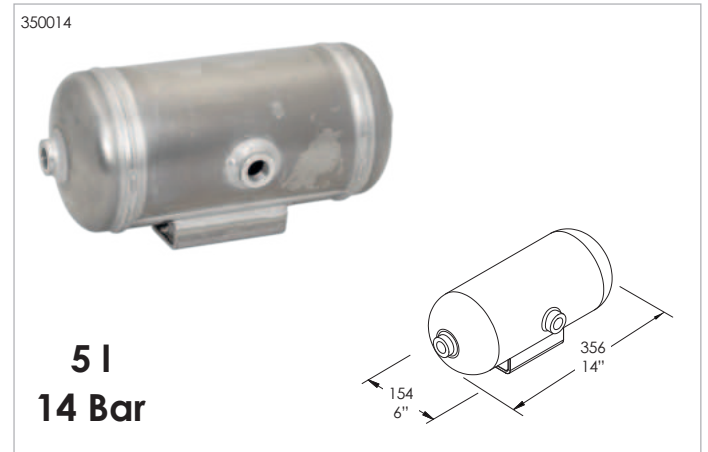
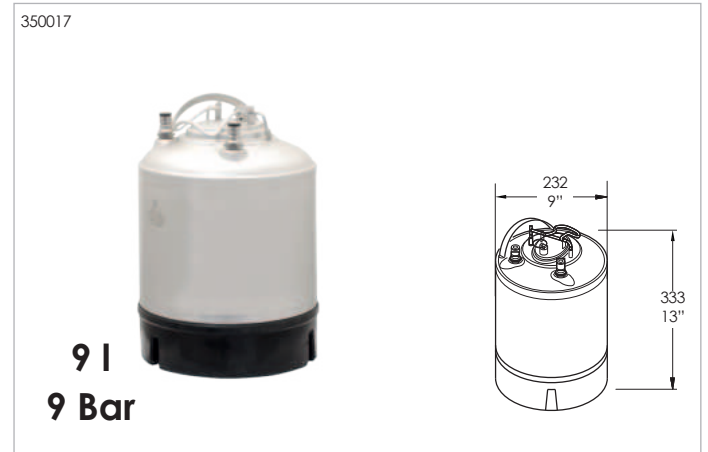
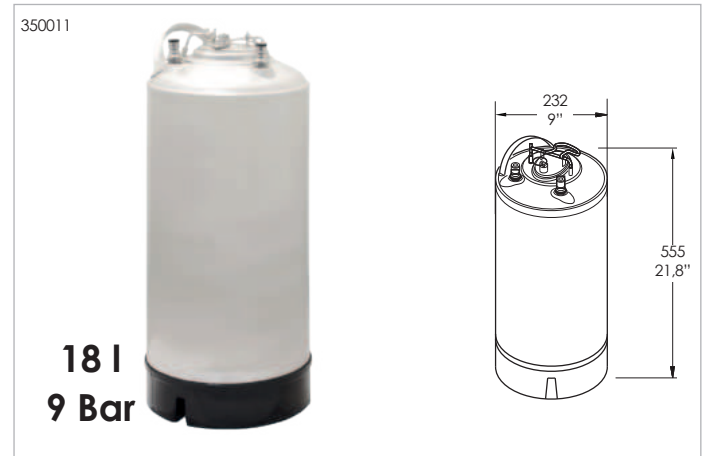

Cod.	lt	US G	Material	A B C (cm)	A B C (inch)	(Kg)
350011	18	5	Inox	56,35 x 23,2	21,8" x 9"	3,35
350017	9	3		34 x 23,2	13" x 9"	2,6
350014	5	1,32	Aluminum	17 x 37 x 19,5	6,7" x 14,5" x 7,7"	2
350040	5	1,32	Carbon Steel	13,5 x 33 x 18	5,3" x 13" x 7"	3,5
350041	10	2,64		20,5 x 54 x 21,5	8" x 21" x 8,5"	6
350042	15	41		20 x 59 x 26,5	7,8" x 23" x 10,5"	9,5
350012						
350013						



Solenoid valves

Specifications:

- Bayonet tube, patented system allowing quick manual inspection of the pilot.
- Rubber coil stop, elastic ring ensuring coil's fixing without tools.
- High precision mechanical machining to obtain the lowest rate of roughness to limit limestone adherence.
- High resistance to corrosion thanks to the inner stainless steel parts with low magnetic residue, specific for solenoid valves.
- Operating range from -10°C to 50°C;
- Fluids temperature from -10°C to 130°C;

Materials used:

- Brass body CW617N (EN 12165)
- Stainless steel inner parts
- AISI 303 stainless steel tube (EN 10088-3)
- Seals in FPM (Viton), NBR, EPDM, silicone.

Elettrovalvole

Caratteristiche tecniche:

- Cannotto a baionetta, sistema brevettato per una rapida ispezione manuale del pilota.
- Ferma bobina in gomma, anello elastico per il fissaggio della bobina senza attrezzatura.
- Lavorazioni meccaniche di alta precisione per garantire il minor grado di rugosità e limitare l'adesione del calcare.
- Alta resistenza alla corrosione grazie agli organi interni in acciaio inox a basso residuo magnetico, specifico per elettrovalvole.
- Temperatura di funzionamento da -10°C a +50°C;
- Temperatura dei fluidi da -10°C a +130°C;

Materiali utilizzati:

- Corpo in ottone CW617N (EN 12165)
- Organi interni in acciaio INOX
- Cannotto in acciaio INOX AISI 303 (EN 10088-3)
- Materiali tenuta in FPM (Viton), NBR, EPDM, silicone.

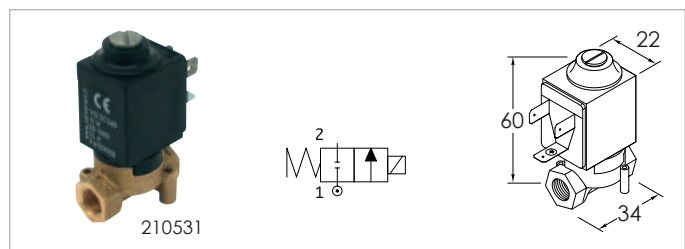
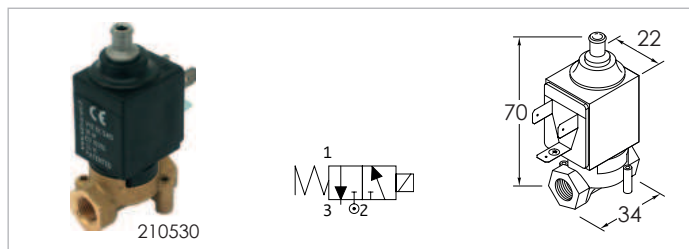
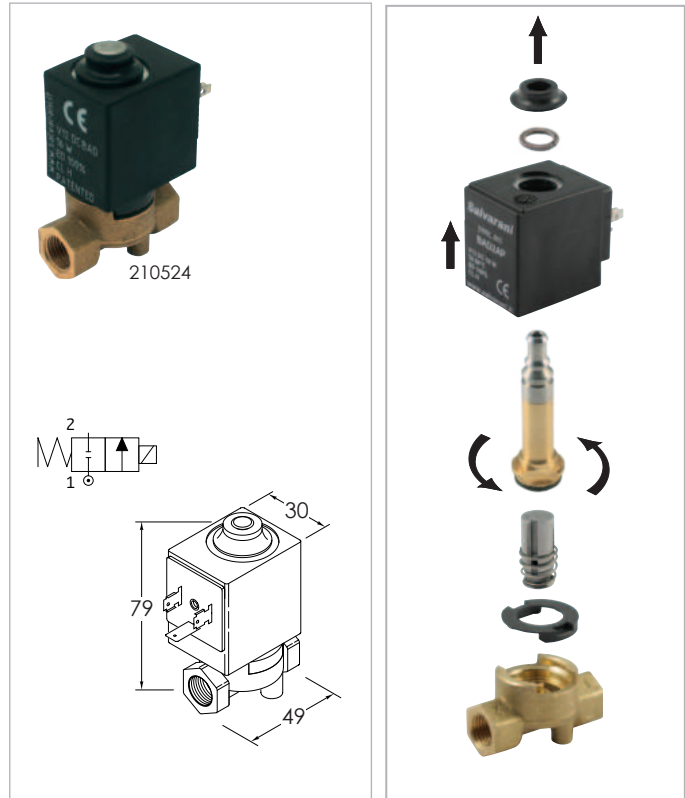

Cod.	n° Outlet	Pressure (bar)	Q Max (l/min)	ø int. (mm)	Fittings	V (V dc)	P max (W)	
210524	2	0-8	4,5	3	1/4"	12	16	5
210531	2	0-2	3,5	3	1/8"	12	10	5
210537	2	0-8	4,5	3	1/4"	24	16	5
210530	3	0-2	2,7	2,5	1/8"	12	10	5
210532	3	0-8	1	1,5	1/8"	12	10	5

Elettrovalvole a collettore - Manifold solenoid valves

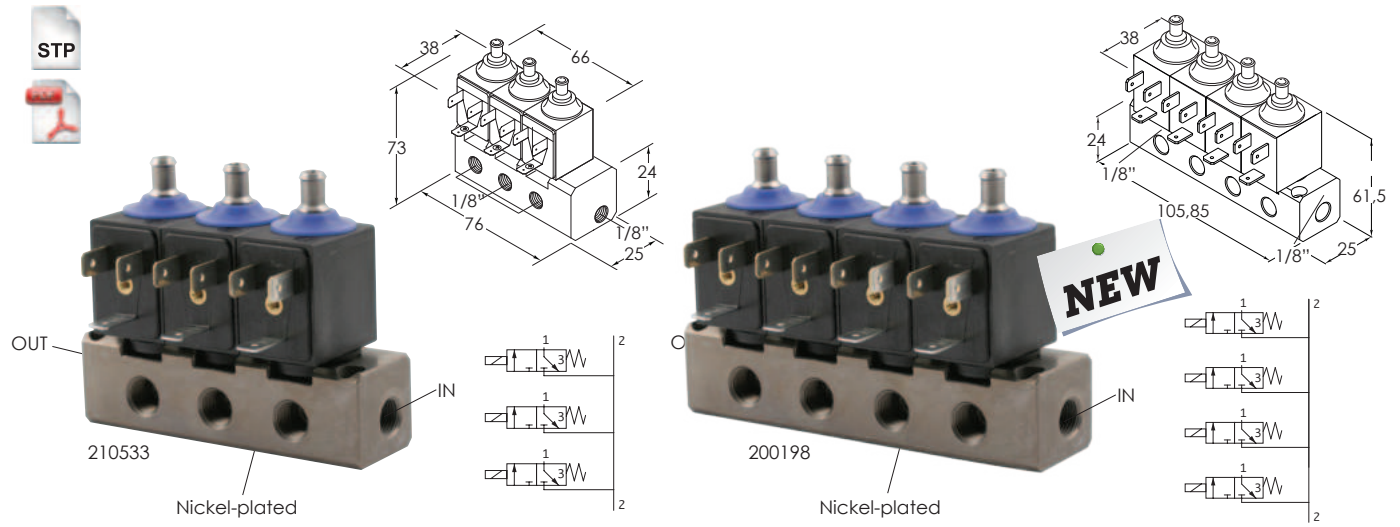

Cod.	n° Outlet	Pressure (bar)	Q Max (l/min)	ø int. (mm)	Fittings	Material	Vdc	P max (W)	
210533	3	0-8	1,0	1,5	1/8"	Nickel-plated	12	30	1
200198	4	0-8	1,0	1,5	1/8"	Nickel-plated	12	40	1

Pneumatic Air Control Box

3-way or 4-way solenoids manifold to control pneumatic nozzles.

Valve block integrated in an IP65 box with air vent hole. Available in two versions for the direct control of 3 or 4 solenoid valves with 1,5 mm2 hole and Ø 8 mm inlet and Ø 4 mm outlet fittings. Possibility of customizations with electrical configurations and air inlet/outlet fittings to adapt to various types of pneumatic systems.

Gruppo elettrovalvole a 3 o 4 vie per il comando di antigoccia pneumatici.

Gruppo valvole alloggiato in una scatola IP65 con foro di sfogo. Disponibile in due versioni per il comando diretto di 3 o 4 elettrovalvole con orifizio da 1,5 mm2 e raccordi Ø 8 mm in entrata e Ø 4 mm in uscita. Possibilità di personalizzazioni con configurazioni elettriche e raccordi aria per adattarsi a vari tipi di antigoccia pneumatici.

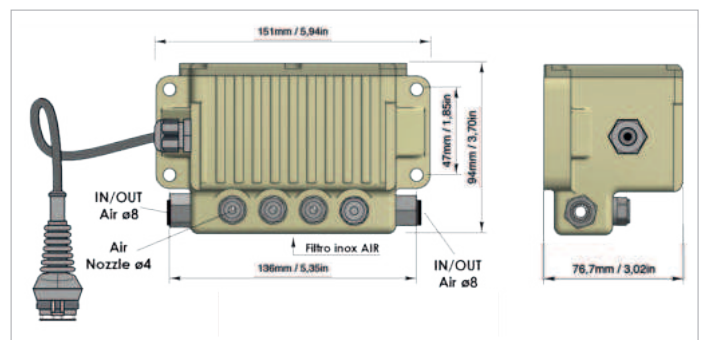
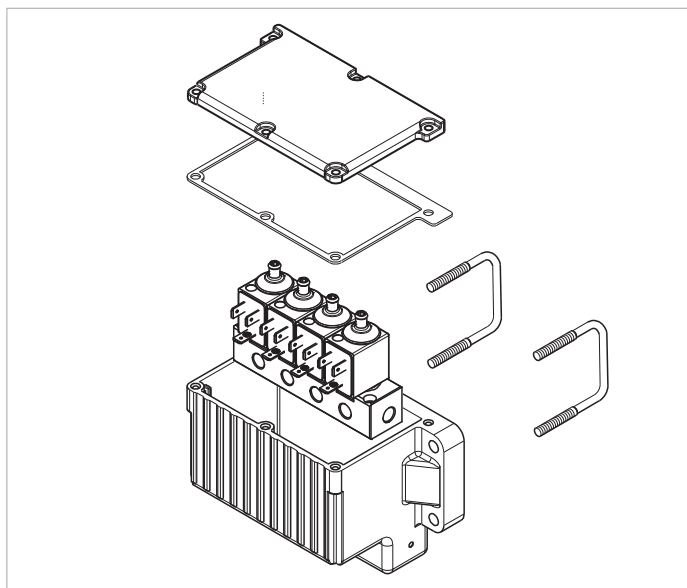

Cod.		# Sections	IN/OUT Air (mm) - (in)	Air (mm) - (in)	Command	A unit	VDC	Available	N° unit Boom	Electrovalve MAX Boom
903605.03	central right/left	3	ø 8 0,3"	ø 4 0,15"	Direct cable	3,0	12	✓	8	~24
903605.04	central right/left	4	ø 8 0,3"	ø 4 0,15"	Direct cable	3,5	12	✓	6	~24

■ ■ Raccordi in plastica o calzamento

In poliammide caricato vetro (PA6 + 30GF).

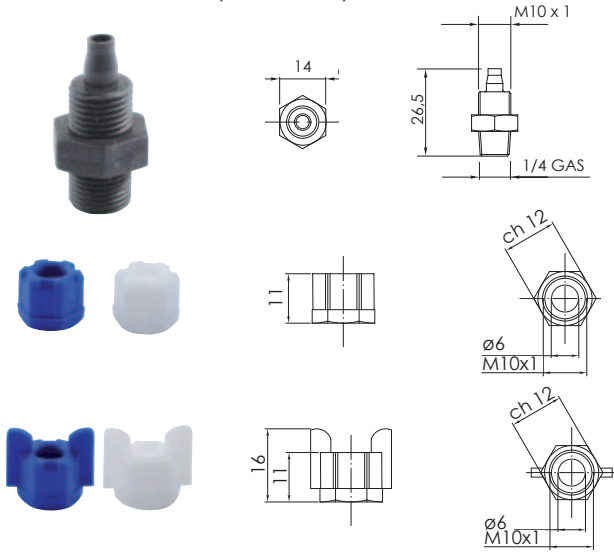

■ ■ Plastic fittings

Glass-filled polyamide (PA6 + 30GF).

Cod.	Description / Notes	Filetto/ Thread GAS	Tubo/ Tube Ø	Bar	
200037	1/8" straight fitting, 6x4 tubing	1/8	6/4	6	100
200042 200036	6x4 blue ring nut 6x4 white ring nut		6/4 6/4	6 6	100 100
200044 200043	6x4 blue ring nut 6x4 white ring nut		6/4	6	100 100

■ ■ Raccordi in plastica porta tubo 8/6

■ ■ Plastic hose fittings

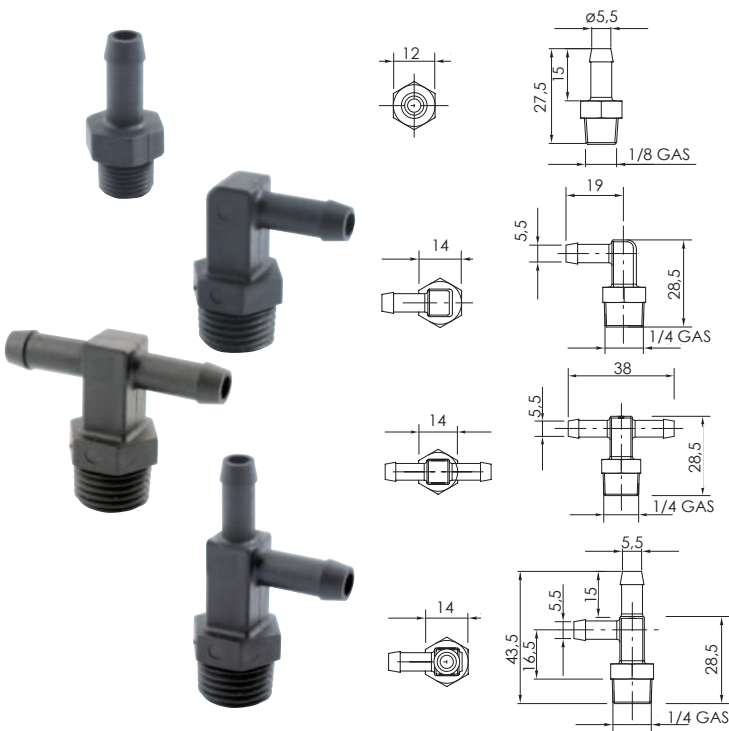

Cod.	Description / Notes	Filetto/ Thread GAS	Tubo/ Tube Ø	Bar	
200138	1/8" straight fitting, 8x6 hose holder	1/8	8/6	2	100
200139	1/4" elbow fitting, 8x6 hose holder	1/4	8/6 1/4"	2	100
200154	1/4" double elbow fitting, 8x6 hose holder	1/4	8/6 1/4"	2	100
200190	Racc.a 'T' Laterare 6-8 1/4" Gas M Conico PLT	1/4	8/6 1/4"	2	100

■ ■ Adattatori

■ ■ Adapters

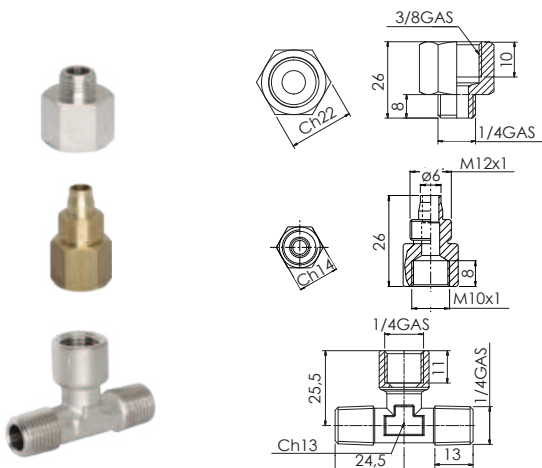

Cod.	Description / Notes	Filetto/ Thread GAS	Tubo/ Tube Ø	
200122	Riduzione F 3/8 M 1/4 Ottone	3/8 - 1/4		10
901187	Riduzione 6x4 F - 8x6 M a Calzare		6	10
200232	Raccordo T M.F.M. 1/4"	1/4		10

Raccordi ottone nichelato a calzamento

Nickel plated brass fittings

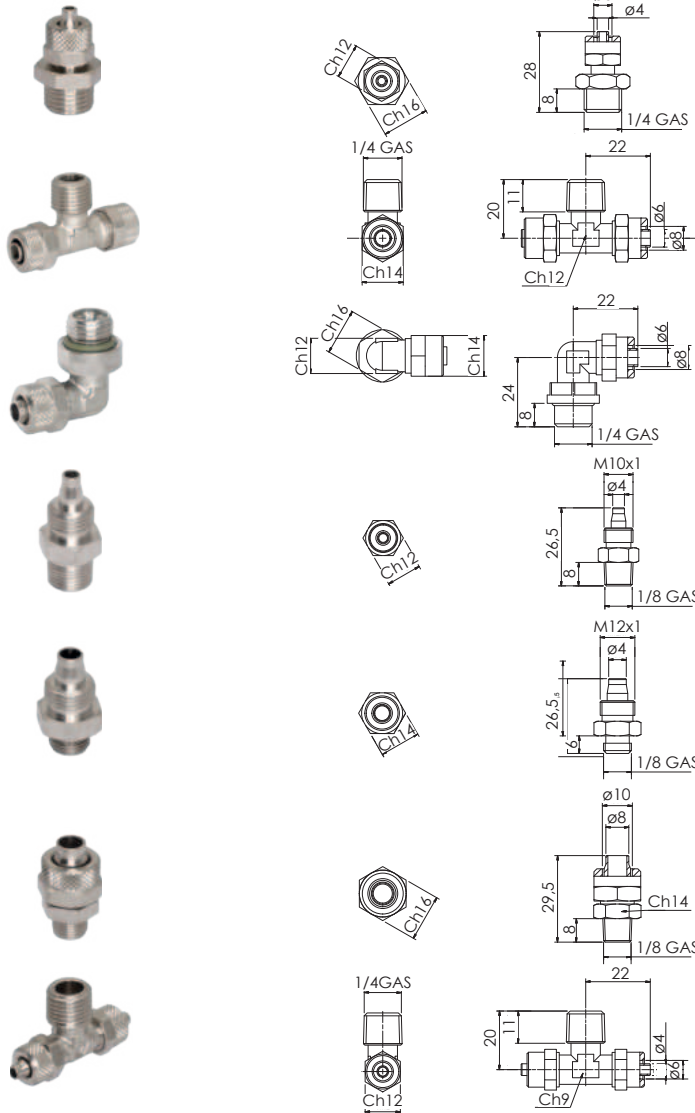

Cod.	Description / Notes	Filetto/Thread GAS	Tubo/Tube Ø	Bar	
200048	Racc. Corpo Dir.m.cil.1/4" 6x4	1/4	6/4	15	10
200081	Racc. T Centr. Conico 1/4"-8/6	1/4	8/6	15	10
200206	Racc. Gir. A Calzare 1/4m - 8 Viton	1/4	8/6	15	10
200039	Racc. Corpo Dir. 1/8-6X4 OT	1/8	6/4	15	10
200023	Racc. Diritto 1/8" 8X6	1/8	8/6	15	10
200026	Racc. Diritto 1/8" 10X8	1/8	10/8	15	10
200005	Racc. T 6X4-1/4"-6X4	1/4	6/4	15	10

Raccordi ottone nichelato a innesto rapido

Quick nickel plated brass fittings

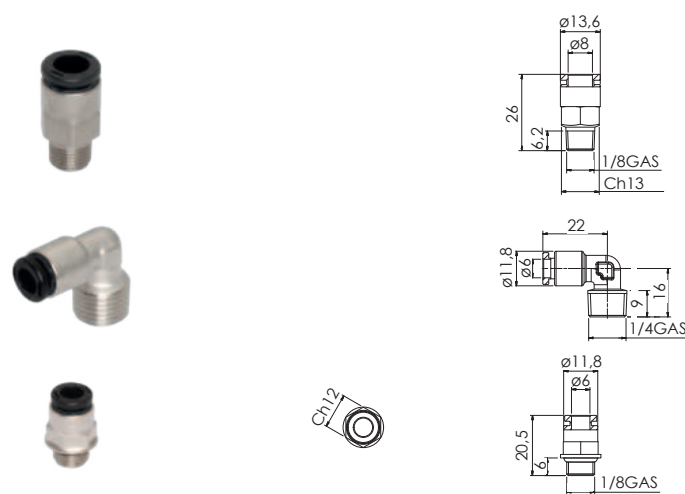

Cod.	Description / Notes	Filetto/Thread GAS	Tubo/Tube Ø	Bar	
200051	Racc. Diritto 1/8" - 8	1/8	6	16	10
200009	Racc. Angolo 1/4" - 6	1/4	6	16	10
200029	Racc.diritto 1/8" M CIL - 6	1/8	6	16	10

Raccordi in plastica a innesto rapido

Quick Plastic fittings

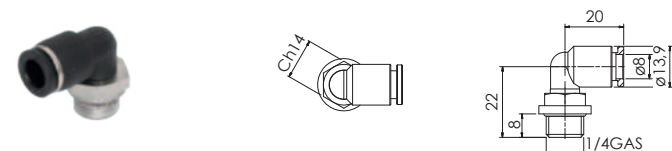

Cod.	Description / Notes	Filetto/Thread GAS	Tubo/Tube Ø	Bar	
200059	Racc. L M. Cil. Gir. 8-1/4 Tecnop.	1/4	8	12	10













■ ■ Tubazioni in plastica

In PA12 (Rilsan), poliuretano e polietilene.

🇬🇧 Plastic tubing

Made of PA12 (Rilsan), Polyurethane and Polyethylene.



Cod.	Size (Out x In, mm)	Color	Material	Temp. Range (° C)	Max Work Pressure (atm)	
230009	6 x 4 (3,8)		Polyurethane	-40 ÷ +60	11	100 m
230023	6 x 4 (3,8)	Transpa- rent				
230032	8 x 6 (5,7)		Polyurethane	-40 ÷ +60	8	100 m
230026	8 x 6 (5,7)	Transpa- rent	Polyurethane			
230041	10 x 14	Transpa- rent	Polyurethane 98MB		11	
230031	4 x 2		PA11 (Rilsan)	-40 ÷ +80	44	100 m
230006	6 x 4					
230005	6 x 4					
230028	6 x 4					
230017	8 x 6		PA11 (Rilsan)	-40 ÷ +80	19	100 m
230024	8 x 6					
230042	12x10					
927253H	4 x 2		Polyethylene	-10 ÷ +60	21	100 m
230038	6 x 4					



299111

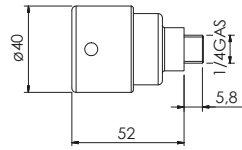

350403

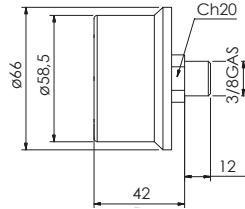

200083.02

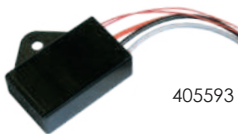
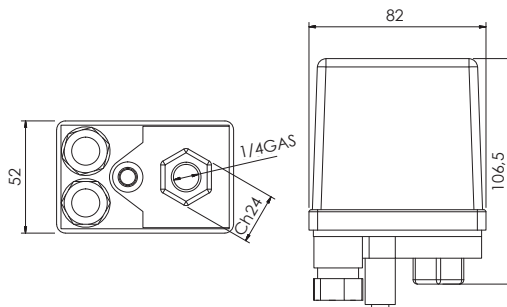

405593



790005-6

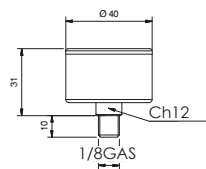

790016-6
790016-12

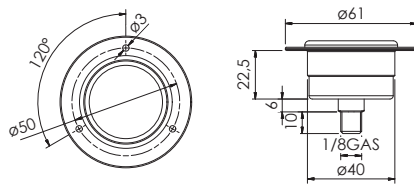

200233

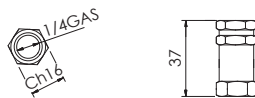

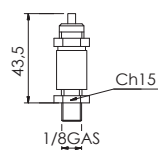

200197



Cod.	Description / Notes	Filetto/ Thread/ GAS	
299111	Filtro Aria Compressa M	1/4	
350403	Filtro Aria Compressa M	3/8	
200083.02	Pressostato Tarato 8 Bar		
405593	Scheda termica motori completa		
790005-6	Manometro 0-6 D.40-AP-1/8" ABS	1/8	
790016-6	Manometro 0-6 D.40-AP-1/8" ABS+FL.	1/8	
790016-12	Manometro 0-12 D.40-AP-1/8" ABS+FL.	1/8	
200233	Valvola Non Ritorno 1/4	1/4	
200197	Valvola di Sicurezza 1/8" 8 Bar	1/8	

Legend

CF / min	
USG / min	
lit / min	
Duty cycle	
IP	
Power W	
V / DC	
AC	

	Disegno 3D disponibile 3D drawing available
	Scheda tecnica disponibile Technical sheet available

BAR	PSI	MPA
1	14,5	0,1
2	29,0	0,2
3	43,5	0,3
4	58,0	0,4
5	72,0	0,5
6	87,0	0,6
7	101,5	0,7
8	116,0	0,8
9	130,5	0,9
10	145,0	1,0

Portata

Flow conversion table

Unit	US customary	Metric
1 USG/min 1 CF/min	-	3,785 L/min 28,31 L/min
1 L/min 1 L/min	0,264 USG/min 0,0353 CF/min	-

Duty Cycle:

CEI EN 60034-1

Per Duty Cycle si intende la percentuale di tempo per la quale un compressore può essere in funzionamento in un certo periodo a una certa pressione in ambiente a 22 °C. Si esprime comunemente in percentuale: $\text{Compressore su "on"} \div (\text{Tempo "on"} + \text{tempo "off"}) = \% \text{ Duty Cycle}$. S1 indica servizio continuo. Nota: tutti i compressori, indipendentemente dal Duty Cycle indicato, richiedono un sufficiente tempo di riposo tra un ciclo e l'altro per permettere un parziale o completo raffreddamento. I periodi di raffreddamento possono variare in funzione della temperatura ambiente e delle condizioni operative.

Tutti i compressori Salvarani sono testati ad una temperatura ambiente di 22 C° con una tensione di alimentazione di 13,8 Volt per i modelli a 12 Volt.

Duty cycle refers to the amount of time a compressor can be operated in a given time period at 100 PSI, and a standard ambient temperature of 72° F. It is commonly expressed in percentage format: $\text{Compressor on time} \div (\text{on time} + \text{off time}) = \text{Duty Cycle \%}$. S1 continuous service. Please Note: All compressors, regardless of rated duty cycle, require sufficient rest time in between cycles to allow for partial or complete heat dissipation. Heat dissipation rates may vary depending on ambient temperatures and operating conditions.

All Salvarani compressors are tested at an ambient temperature of 22 C° with a supply voltage of 13.8 volts for 12-volt models.



Compressore a membrana
Diaphragm compressor













Compressore a pistone
Piston compressor

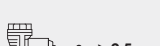

Funzionamento a secco
No oil required

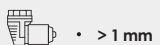
DIN EN 60529

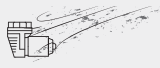
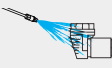
IP Protection

Grado Grade	Solidi Solids	Grado Grade	Acqua Water
1	 ● > 50 mm	1	
2	 ● > 12 mm	2	 ± 15°
3	 ● > 2,5 mm	3	 ± 60°
4	 ● > 1 mm	4	
5		5	
6		6	 Press

	Paese	Tipo filetto
BSPP	EUROPA SUD AMERICA ASIA/OCEANIA AFRICA	55° CILINDRICO
NPT	USA CANADA	60° CONICO

Portata corrente per sezione del cavo Current rate per cable section

Ø	A uso continui continuous use	A uso interrotto interrupted use
1	5	12
1,5	8	16
2,5	13	28
4	22	45
6	33	69
10	55	115
	Caduta di tensione Fall of voltage < 1V	Caduta di tensione Fall of voltage < 2V
Cavo/Cable 5m - T.30°C		

■ ■ Guida per la scelta del Compressore
🇬🇧 Specification guide for Compressor choice

Azienda / Company name _____ Data / Date _____

Città / City _____ Provincia / County _____ Stato / Country _____ CAP / Zip code _____

Tel. _____ Fax _____ Email _____ Website _____

Richiedente / Applicant: _____ Mansione / Job: _____

Settore di utilizzo:
Field of use:

Tipo di applicazione:
Type of application:

- Industria / Industry _____
- Agricultural / Agriculture _____
- Automotive _____
- Elettromedicale / Electromedical _____

1) Alimentazione / Power Supply

12 V dc | V DC _____ | V AC _____ Hz _____

24 V dc

Grado IP di Protezione motore / IP motor protection rate _____

2) Ciclo di funzionamento / Functioning cycle

Continuo / Continuous | Intermittente / Intermittent

Tempo funz. min. _____ Tempo pausa min. _____

Min. operating time _____ Min. pause time _____

Altro / Other _____

3) Temperatura ambiente / Ambient temperature

Min. _____ °C _____ °F | Max _____ °C _____ °F

4) Requisiti di pressione e portata / Pressure and flow details

Flusso di funzionamento Max / Max operating flow _____ L/min _____ bar _____ GPM _____ PSI

Flusso di funzionamento Min / Min operating time _____ L/min _____ bar _____ GPM _____ PSI

5) Tipo di controllo / Type of control

Pressostato / Pressor switch | Con serbatoio di accumulo / With accumulating tank Lt. _____ | Senza serbatoio

Manuale / Manual | Timer | Altro / Other _____

6) Configurazione della tubazione del sistema / Hosing system configuration

_____ Ø Interno Tubazione / Internal hose Ø _____ Lunghezza / Length _____

Worldwide retailers

Russia:

Spraying Technologies, LLC
Moscow - Russia
info.ru@spray.com

Ukraine:

Bondioli & Pavese LLC
Temopil - Ukraine
www.bondioli-pavese.com

Cina:

Leixina
www.leixina.com

Australia:

Agrispartes
Cavan - South Australia
www.agrispartes.com.au

Romania:

SC Salvarani ROM srl
Segarcea - Romania
www.gpsagricol.ro

South Africa:

Monitor Engineering
PYT (LTD)
Johannesburg - South Africa
www.spray-nozzles.co.za

Greece:

Promex Ltd
Thessaloniki - Greece
www.promex.gr

Hungary:

Farmcenter KFT.
Godollo - Hungary
www.farmcenter.hu

Spain:

Bondioli Y Pavese Iberica SA
Zaragoza - Spain
www.bondioli-pavese.com

Salvarani srl

Poviglio (RE) - Italy
www.salvarani.com

Uruguay:

Suragric sa
Montevideo - Uruguay
www.sma.com.uy

Brazil:

Herbicat Ltda
Catanduva - Brazil
www.herbicat.com.br

Argentina:

Spraytec srl
Rosario - Argentina
www.spraytec-srl.com.ar

Canada & USA:

SNA MFG LLC
www.snamfg.com

Chile:

Sargent Agrícola
Santiago - Chile
www.sargent.biz

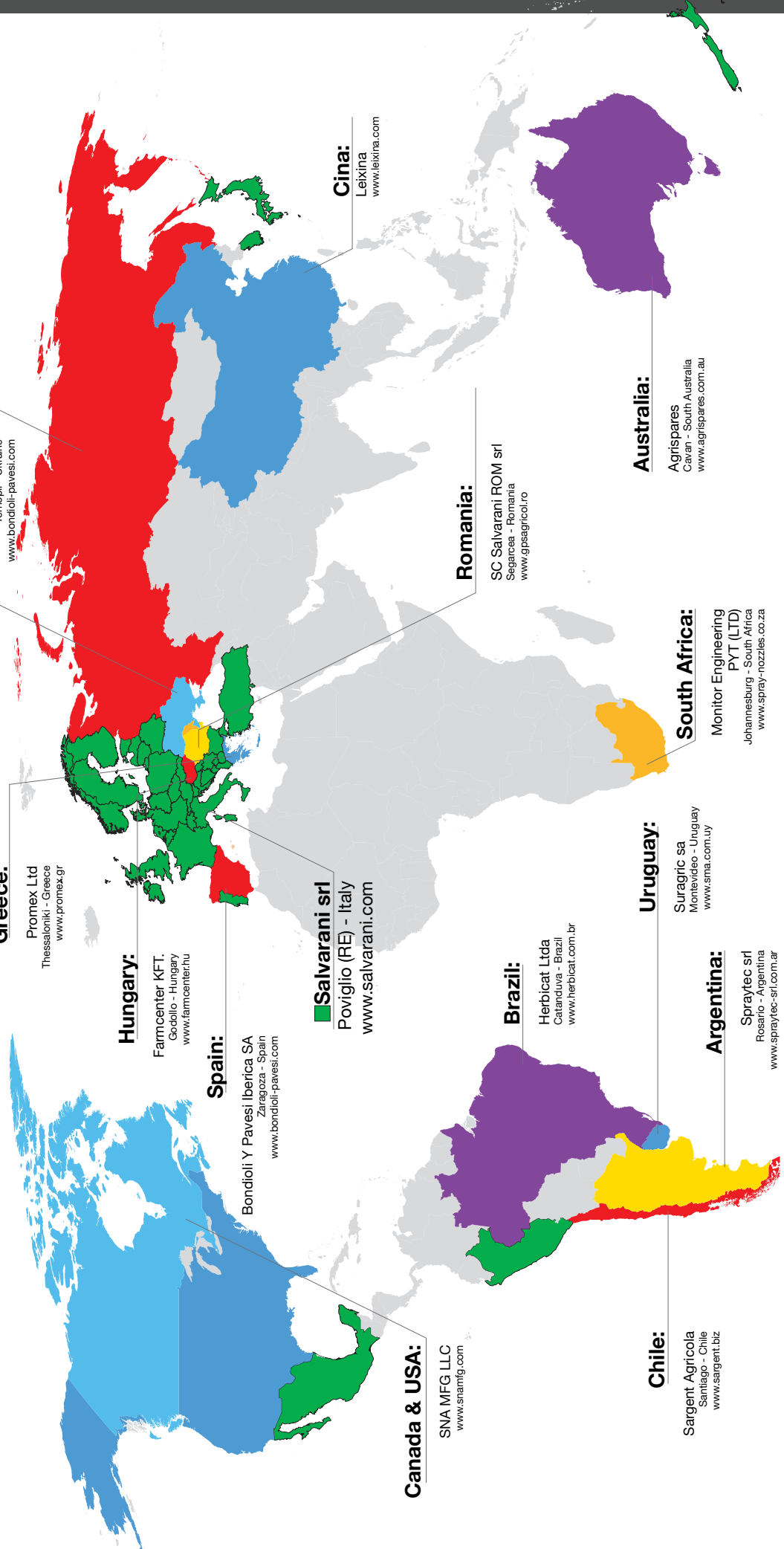



Salvarani s.r.l.
Via M. Buonarroti, 2
42028 Poviglio (RE) - Italy
Phone +39 0522 969177
E-mail info@salvarani.com
www.salvarani.com